

FI EARTH LEAKAGE CIRCUIT BREAKERS

FI compact Earth Leakage Circuit Breakers detect and interrupt earth (ground) faults. They are VDE approved for the European system of protecting people, animals, equipment and property from dangerous line-to-ground and shock hazard currents.

US applications include ground-fault protection of equipment (GFPE) using the 10mA and 30mA fault current ratings, especially when high distributed capacitance or other leakages cause excessive nuisance trips at lower fault currents. Applications for the 300mA rating are equipment protection and fire prevention, limiting the energy of a fault to less than the minimum ignition energy for many materials.

Type Designation

$$FI \overline{(a)} \overline{(b)} \cdot \overline{(c)}$$

- (a) = 2-2 pole; 4-4 pole
- (b) = 1-16A; 2-25A; 3-40A; 4-63A
- (c) = 01 - 10mA
 = 03 - 30mA
 = 30 - 300mA



FI 2



FI 4^a

Maximum Rated Line Current	Fault Trip Current	Type	Cat. No.		Fault Trip Current	Type	Cat. No.	
16A	10mA	FI 21.01	15.921					
25A	30mA	FI 22.03	15.922		30mA	FI 42.03	15.926	
25A	300mA	FI 22.30	15.924		300mA	FI 42.30	15.929	
40A	30mA	FI 23.03	15.923		30mA	FI 43.03	15.927	
40A	300mA	FI 23.30	15.925		300mA	FI 43.30	15.930	
63A					30mA	FI 44.03	15.928	
63A					300mA	FI 44.30	15.931	
Earth Leakage Circuit Breaker with Auxiliary Contacts^b					Earth Leakage Circuit Breaker with Auxiliary Contacts^b			
25A	30mA	FI 22.03Y	15.932		30mA	FI 42.03Y	15.933	
40A	30mA	FI 23.03Y	15.934		30mA	FI 43.03Y	15.935	
63A					30mA	FI 44.03Y	15.936	

Voltage Rating (maximum)	240VAC, 50/60Hz (VDE: 125/220VAC, 50Hz)	415VAC, 50/60Hz (400Hz available on request) (VDE: 220/380VAC, 50Hz)
Short Circuit Capacity	Up to rated current (RC) 40A = 1.5kA, RC 63A = 2kA. 10kA in combination with series fuse of European Operation Class gL/gG: RC 16A = 63A fuse, RC 20/40A = 80A fuse, RC 63A = 100A fuse.	
Fault Trip Current Calibration	FI trips are calibrated at less than fault trip current for ensured safety (Typical trip range between 66.6-83.3% fault trip current, e.g., typical trip at 20-25mA for fault RC of 30mA)	
Typical Life	Fully functional after 4,000 operations to DIN/VDE 0664 (CEE27) and 16000 additional fault current trips.	
Standard Pack and Weight	1/290g (0.64 lb.); 1/390g (0.86 lb.) with auxiliary contact	1/450g (1.0 lb.) 1/550g (1.21 lb.) with auxiliary contact
Terminal Size Acceptability	16-6 AWG	14-3 AWG
Equivalent Circuit		

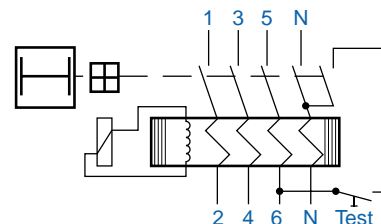
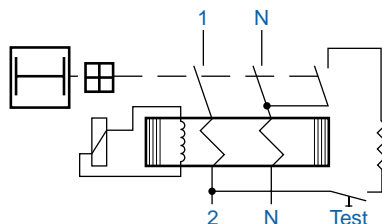

^a For 2-Phase applications, terminal 5 and 6 (next to Neutral terminals) must be connected to one phase for the test circuit to be operable.

^b Provided with mounted Auxiliary Switch, one N.O., one N.C. isolated feedthrough contact (Form X double make and Y double break), which adds 9mm (.35 in.) to the width dimension.

Note: If the power system has a marked conductor, it must connect through the FI and not be grounded at any point downstream.

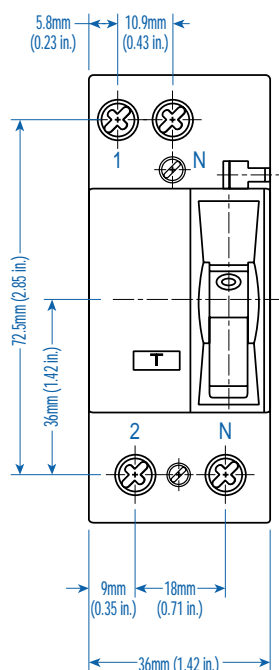

FI 2

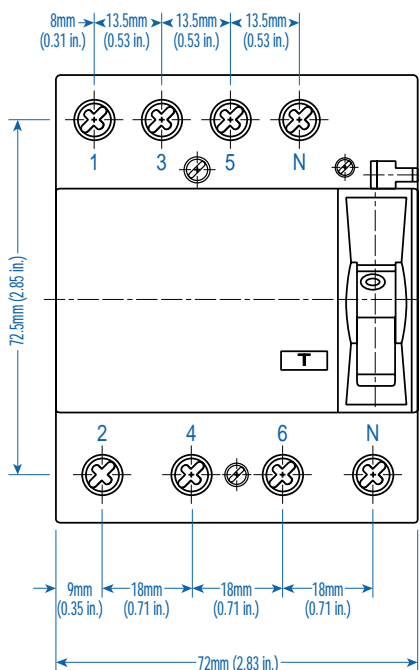

FI 4

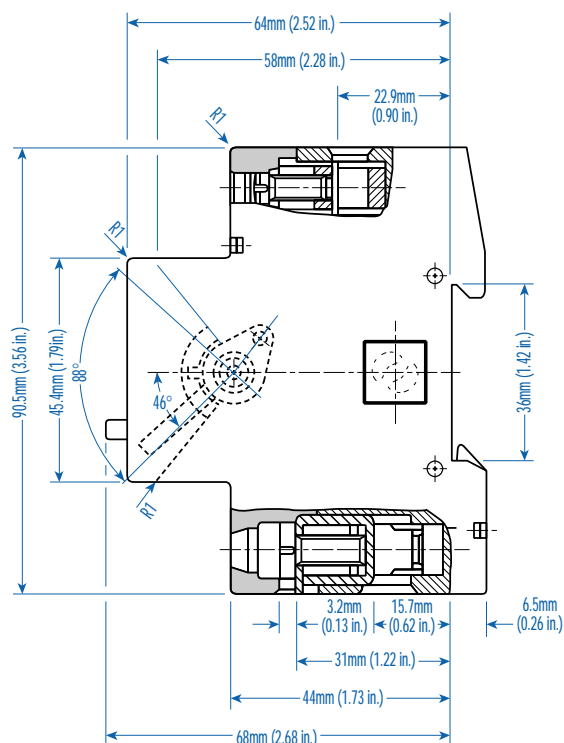

FI 2 and FI 4

Temperature Range	Environmental Information marked with "Snowflake" approval for -25°C to 40°C (-13°F to 104°F) ambient temperature. (Temperature effect on RC: for every 10°C temperature rise above 40°C decrease RC by 7%.)
Fluctuating Climate Conditions	To maximum 45°C, 95% relative humidity.
Electrical Shock Protection	Uninsulated electrically live parts within 30mm of the operating handle are "finger safe" (terminal screw heads) and uninsulated live parts within 100mm of the operating handle are "back-of-hand safe" (terminals).
Impact/Shock Protection	15g with impact force half-cycle sinusoidal and 11ms duration, 18 impacts total with 6 on each principal axis (3 impacts each face). FI is DIN Rail mounted during the test, and electrically loaded with 25% of Fault RC. Successful testing required no trip during the test, no damage and no loosened parts.
Vibration/Seismic Resistance	5g, at frequency of 55Hz to 2,000Hz, applied for 35 ± 5 minutes along each of the three principal axes, plus 5 minutes of application at every established critical resonant frequency. FI is DIN Rail mounted during the test, and loaded with 25% Fault RC. To pass, the FI did not trip at 25% Fault RC, but did trip between each of the principal axis tests when the fault current was raised to 125% Fault RC, and there was no damage and no loosened parts. Suitable for machinery and mobile vehicle applications.
Housing Class	Ingress Protection (IP) Class 40; internal working components and live parts (excluding terminals) are protected against ingress of solid objects greater than 1mm diameter (class 4-), but have no protection from ingress of water (class-0).
Non-Sinusoidal Fault	The FI is tested and approval stamped for tripping sensitivity to non-sinusoidal fault currents, which become zero or almost zero within one cycle of the line frequency. Waveforms and allowed trip-current ranges are as follows: <ul style="list-style-type: none"> 1. AC Sinusoidal Fault - 0.5-1.0 times Fault RC 2a. Pulsating DC Fault; Positive and Negative Half-Waves - 0.35-1.4 times Fault RC 2b. Phased Half-Wave, 90° - 0.25-1.4 times Fault RC Phased Half-Wave, 135° - 0.11-1.4 times Fault RC 3. Pulsating DC on 6mA DC (continuous) Base - Max. 1.4 times Fault RC + 6mA
Insulation Category	At VDE rated voltage, suitable for Class C environments with relatively high dust and moisture levels and little HVAC control, e.g., industrial, commercial, agricultural; on machine tools, hoists, warehouse equipment, etc.; in boiler rooms, unheated storage, covered shipping/receiving, open workshops, etc.