

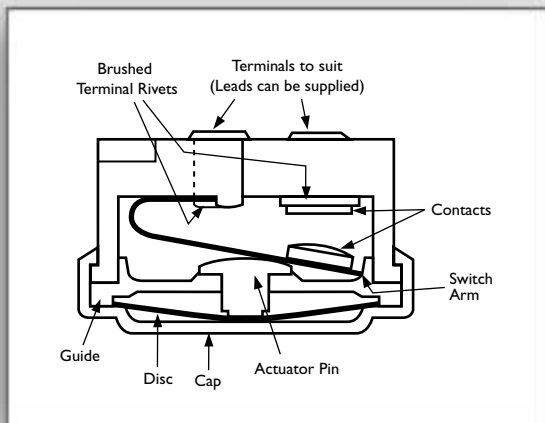

## Airpax Series 5004 Thermostat

Designed with 4mm clearances, and for operation at 240Vac, this small, rugged thermostat is ideally suited for use in Europe, Canada, the U.S. and other geographical areas using 240Vac. General applications include industrial as well as electrical and electronic equipment, such as business machines, computer peripherals, radar, heater blanket controls and heat sink protection.

The switch is operated by a bimetal disc known for its repeat reliability. The construction of the switch assembly offers excellent shock and vibration resistance. Thermal response is rapid due to low mass. If desired, the unit can also be epoxy sealed for harsh environmental applications. The switch is tamper-proof and not adjustable. Various terminations are available for soldering, welding or quick connects. Leads can also be provided. The series 5004 thermostat is UL recognized, CSA certified, and VDE approved.



# AIRPAX®

©Copyright 2000 Airpax · All Rights Reserved · 00095 2/00



### SPECIFICATIONS

- **\*Contact Rating for 100,000 Life Cycles:**  
15A amp resistive, 120 Vac  
10A amp resistive, 240 Vac
- **Contacts:** SPST
- **Temperature Settings:** 35°F to +325°F
- **Dielectric:**  
1500 VRMS 60 cycle 1 min.  
Terminals to case
- **Weight:** 3.4 grams (.12 oz.)
- **Exposure Limit:** -40°F to +350°F

*\*UL recognized to 130°C operating temperature.  
CSA certified to 168°C operating temperature.  
Loads under 100mA, 5Vdc, will require gold-plated contacts, with recommended minimum load of 10mA, 5Vdc.*

## SELECTION CODE CHART

### A Contact Operation

Choose from codes across for specific contact operation (see chart).

#### CONTACT OPERATION

**Code O** = Open on Rise; **Code C** = Close on Rise

### B Basic Series Number

Code 54 for all variations of this thermostat.

To establish your Airpax Thermostat Part Number precisely, choose the proper code letter from the following tables for terminal selection, terminal orientation and mounting selection. Then complete your selection code chart by using temperature specification tables 1 and 2.

## HOW TO USE THIS CHART

Each thermostat P/N (Part Number) consists of functional “building blocks” to enable the user to specify clearly and precisely the desired characteristics in each selection category. Select the proper Code in each category, then transfer it to “Your PN” boxes to the right. Unless a special requirement (Code Z) is indicated, the entries in “Your PN” boxes will accurately specify a standard catalog item.

When Code Z is used, special features (not specified herein) or a unique part number is required, the last four digits from the part number (bottom temperature and tolerance) will be eliminated and a unique four digit number assigned by Airpax will be inserted.

The example shown, records a selection of a standard item with a typical code specified in each “building block” category.

**Note:** See tables 1 and 2 for Operating Temperature Settings and Temperature Tolerances.

#### EXAMPLE PN:

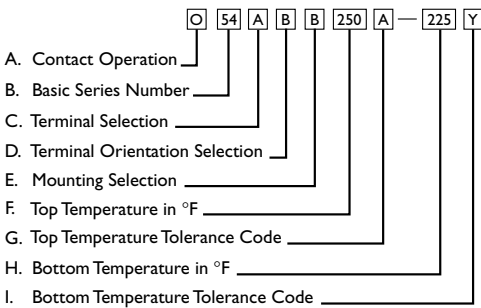

#### YOUR PN:

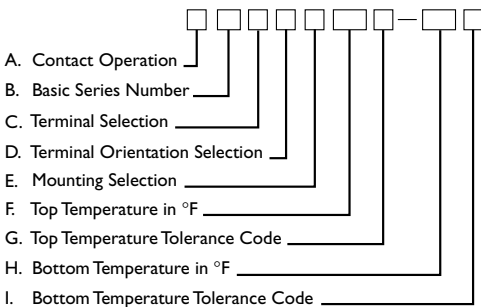

Stamping information to be located on bottom of mounting bracket

## C Terminal Selection

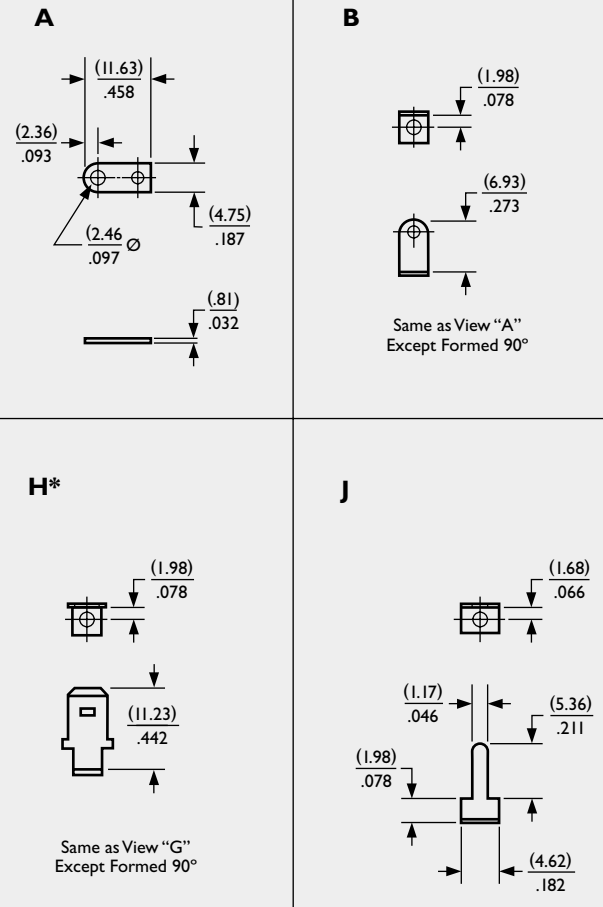

## D Terminal Orientation Selection

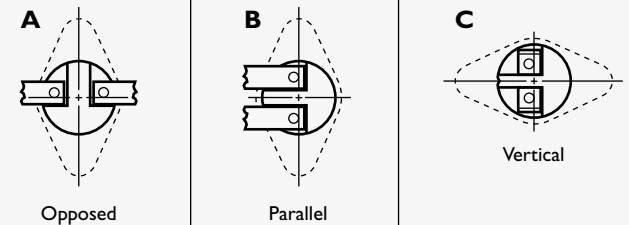

**D** Same as code A and identifies VDE application

**E** Same as code B and identifies VDE application

**F** Same as code C and identifies VDE application

**Z** Special Requirements; Customer to Specify

**NOTES:** The standard lead wire (materials) for different temperature ranges are as follows:

**A.** Up to 220°F (104.4°C) #16 stranded UL 1015 AWN and CSA TEW approved (PVC insulation, color black).

**B.** 221°F to 350°F (105°C to 176.6°C) #16 stranded Type I TFE (Teflon® insulation per MIL-W-22759, color black).

\*Not available with Code “B” terminal orientation

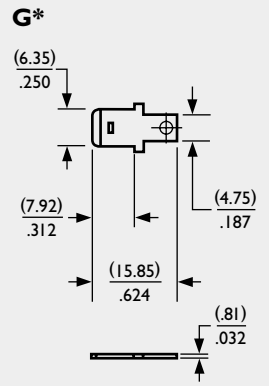
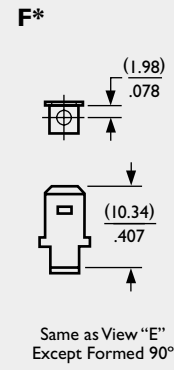
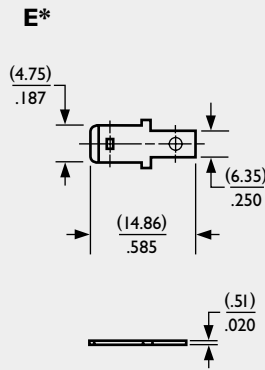
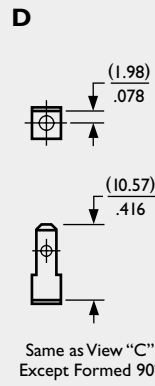
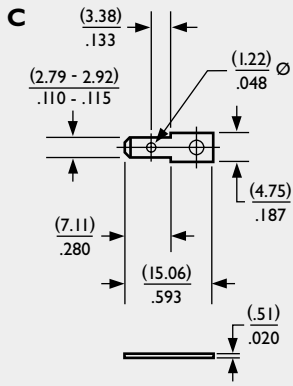

**K** 2 Leads  $\frac{(152.40 \pm 6.35)}{6.000 \pm .250}$   
(See Notes A & B for Lead Wire Specifications)

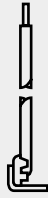

**N** 2 Leads  $\frac{(152.40 \pm 6.35)}{6.000 \pm .250}$   
(See Notes A & B for Lead Wire Specifications)

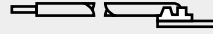

**S** 2 Potted Leads  $\frac{(152.40 \pm 6.35)}{6.000 \pm .250}$   
(See Notes A & B for Lead Wire Specifications)

White Sleeve Standard

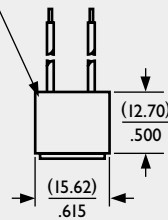

**T** Same as Terminal Selection "S"  
Except 2 Leads  $\frac{(304.80 \pm 12.70)}{12.000 \pm .250}$   
(See Notes A & B for Lead Wire Specifications)

**L** Same as Terminal Selection "K"  
Except 2 Leads  $\frac{(304.80 \pm 12.70)}{12.000 \pm .500}$   
(See Notes A & B for Lead Wire Specifications)

**P** Same as Terminal Selection "N"  
Except 2 Leads  $\frac{(304.80 \pm 12.70)}{12.000 \pm .500}$   
(See Notes A & B for Lead Wire Specifications)

**U** Same as Terminal Selection "S"  
Except 2 Leads  $\frac{(609.60 \pm 19.05)}{24.000 \pm .750}$   
(See Notes A & B for Lead Wire Specifications)

**M** Same as Terminal Selection "K"  
Except 2 Leads  $\frac{(609.60 \pm 19.05)}{24.000 \pm .750}$   
(See Notes A & B for Lead Wire Specifications)

**R** Same as Terminal Selection "N"  
Except 2 Leads  $\frac{(609.60 \pm 19.05)}{24.000 \pm .750}$   
(See Notes A & B for Lead Wire Specifications)

**Z** Special Requirements  
Customer to Specify

**E** Mounting Selection

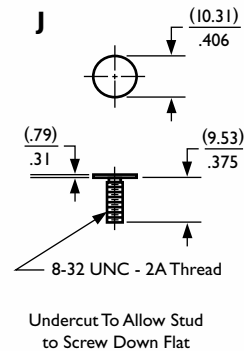
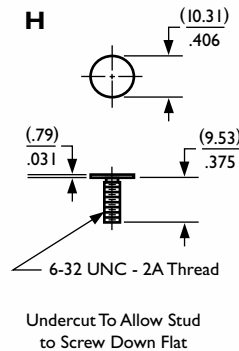
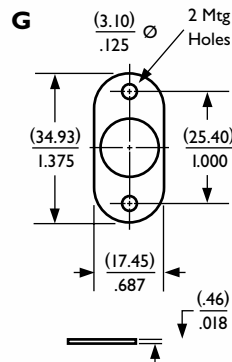
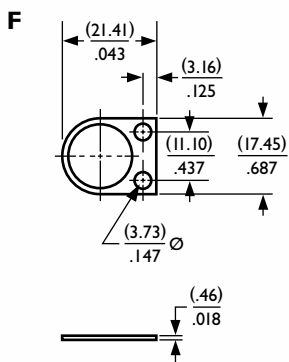
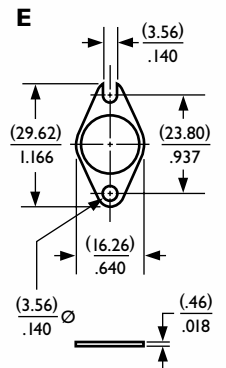
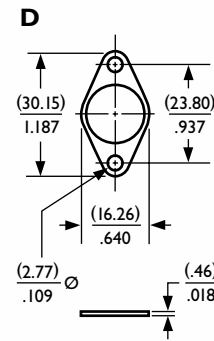
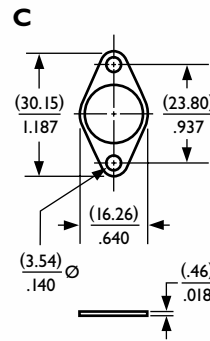
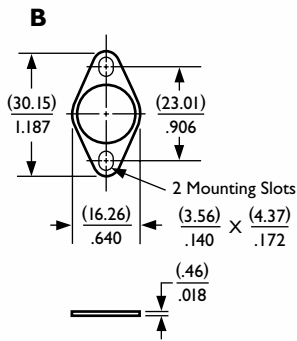
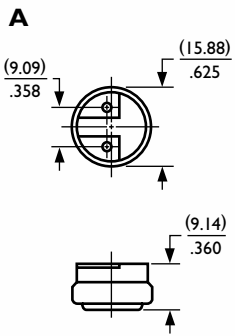

**Z** Special Requirements  
Customer to Specify

TEMPERATURE SPECIFICATIONS

To complete your part number on Airpax Series 5004 Thermostats, the following information and charts will allow completion of “building blocks” F, G, H and I.

Table 1

OPERATING TEMPERATURE SETTINGS

	°F	°C	°F	°C	°F	°C
Temperature Setting	+35° to +200°	-9.4° to +93.3°	+201° to +300°	+93.8° to +148.8°	+301° to +325°	+149° to +162.8°
Standard Tolerance	±5°	±2.8°	±8°	±4.4°	±10°	±5.6°
Standard Nominal Differential	15	8.3	25	13.8	30	16.7

Table 2

STANDARD TEMPERATURE TOLERANCE CODE FOR PART NUMBER SELECTION

CODE	A	B	C	X	Y
±°F	5	8	10	Maximum	Minimum
±°C	2.8	4.4	5.6	Maximum	Minimum

**F Top Temperature in °F**

Select any temperature in the range of 35°F to 325°F. See Table 1.

**G Top Temperature Tolerance Code**

Choose from the codes in Table 2, but don't select a tolerance more restrictive than those specified in Table 1.

**H Bottom Temperature in °F**

The bottom or reset temperature is obtained by subtracting the Standard Nominal Differential of the applicable range (Table 1) from the Top Temperature selected in step F.

**I Bottom Temperature Tolerance Code**

Choose from the codes in Table 2, applying the same restrictions used in selecting the Top Temperature Tolerance in step G. A minimum temperature is standard (“Y” designation).

For tolerances and differentials other than the standards in the above tables, please consult Airpax.

Temperature set point calibration is checked at the factory with precision test equipment traceable to the U.S. National Institute of Standards and Technology and Proven Methods. Because customer checking methods may differ, a typical variance for correlation is ±2°F (±1.1°C).

It is the customer's responsibility to determine whether the product is proper for customer's use and application.

*This information is subject to change without notice.*



©Copyright 2000 Airpax · All Rights Reserved · 00094 2/00

Sensata Technologies, Inc  
 529 Pleasant Street · Attleboro, MA 02703 · USA  
 TEL: 508.236.3800 · FAX: 508.236.2266 · <http://airpax.sensata.com/>